

ETLS14 Linear Motor Actuator



Max. Stroke 1594mm

Max. Speed 2500mm/s

Linear Guide Way 15x13-2

ORDER CODING

ETLS14 - YA020 - C1 - 1270 - A - C 4 - 0001

Model no.

Special order no.

■ Linear Motor Specification

YA020-C1

■ Stroke

838-1594mm
Gap 108

■ Tracked Direction

A	Right
B	Left

■ Home Sensor

External Type	
C	Motor Side
D	Anti-Motor Side
No Sensor	
E	No Sensor

■ Limit Sensor

External Type	
3	1 pc
4	2 pcs
No Sensor	
5	No Sensor

ETLS14 Linear Motor Actuator

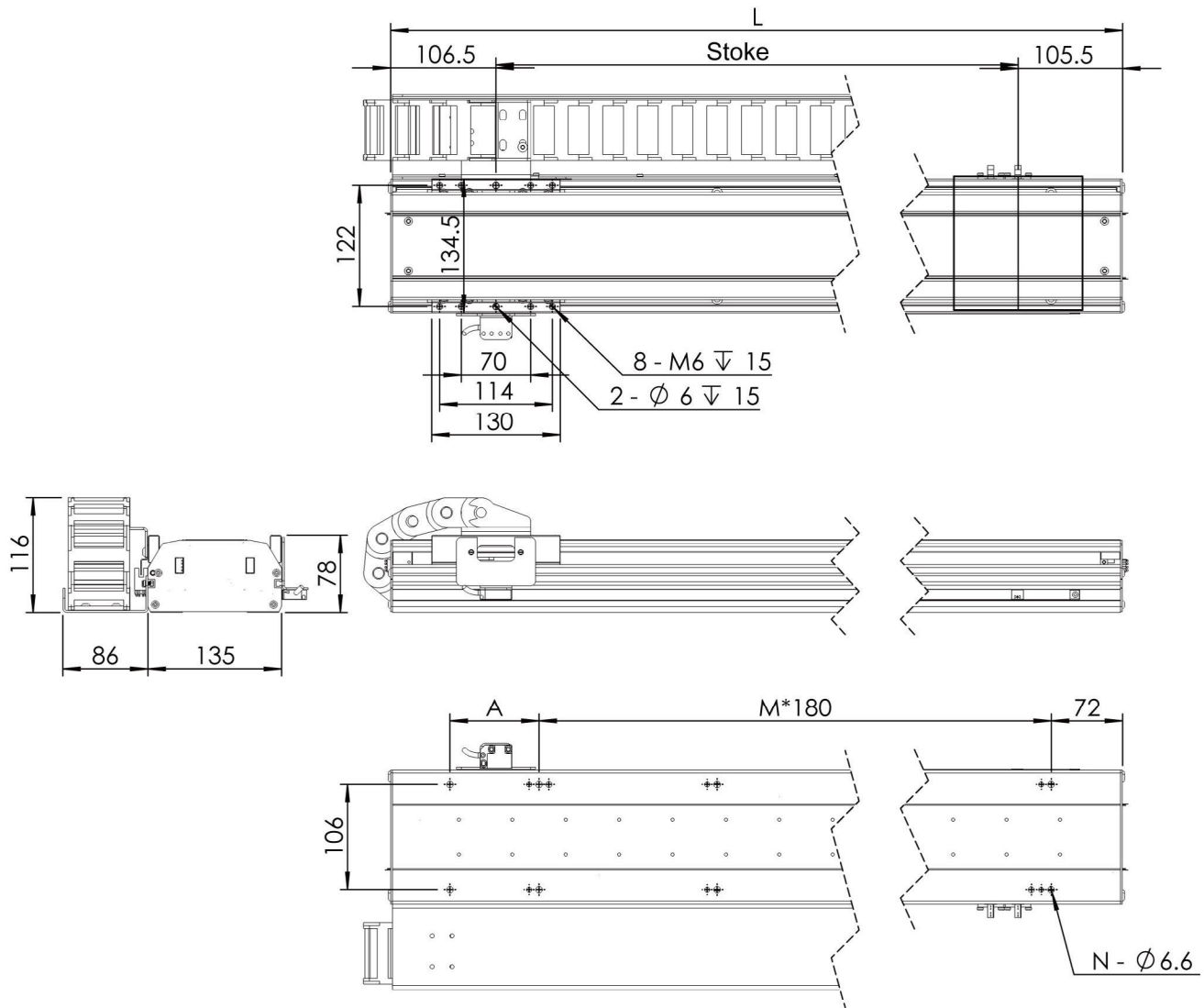

Unit : mm

Stroke	838	946	1054	1162	1270	1378	1486	1594
L	1064	1168	1266	1374	1482	1590	1698	1806
A	-	-	90	-	90	-	90	90
M	5	6	6	7	7	8	8	9
N	12	14	16	16	18	18	20	22