

## Support Unit HF

Pattern : HF15H

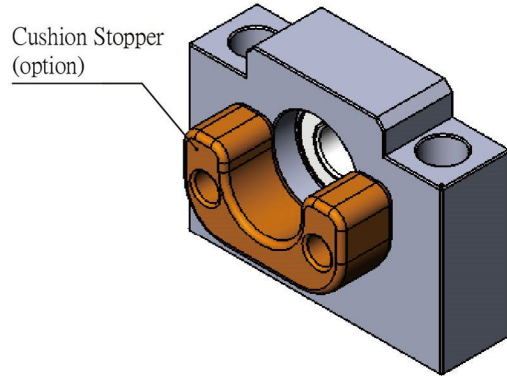
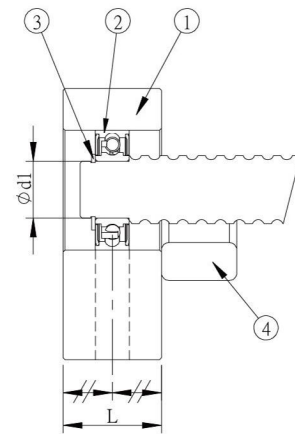
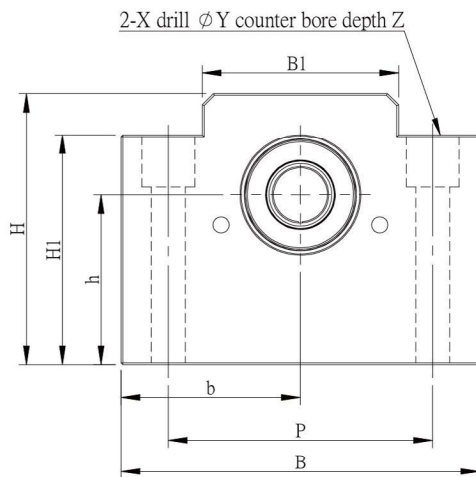

No.	Part name	Qty
1	Housing	1
2	Bearing	1 set
3	Snap ring	1
4	Cushion Stopper (option)	1

**HF**

Unit : mm

Model No.	Shaft diameter d1	L	B	H	b ±0.02	h ±0.02	B1	H1	P	X	Y	Z	Bearing	Snap ring	Weight (Kgs)
HF15	15	20	70	50	35	30	41	40	60	6.6	12	10	6002ZZ	S 15	0.41
HF15H	15	26	95	72	47.5	45	52	61	70	9	14	14	6002ZZ	S 15	1.13