

Motor Bracket MBCB12

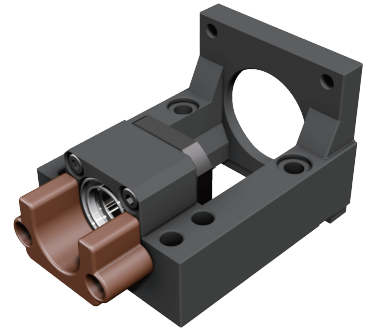

Surface treatment:
Black Oxide / Electroless Nickel Plating

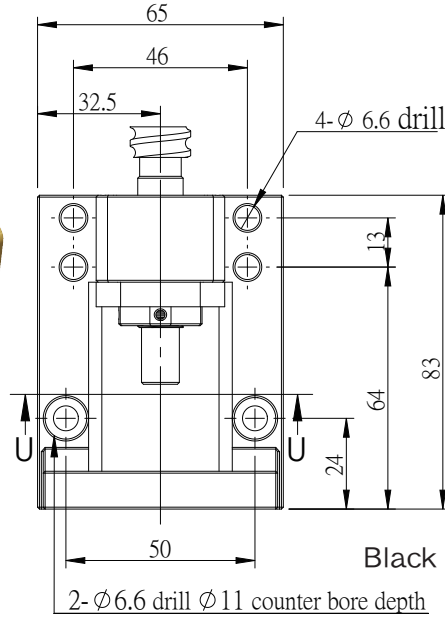
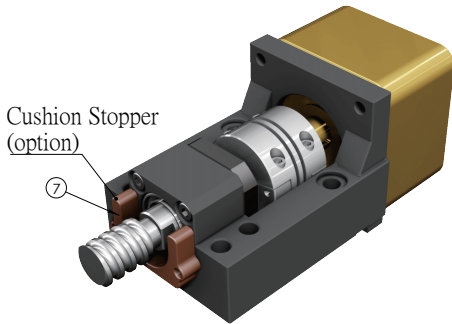
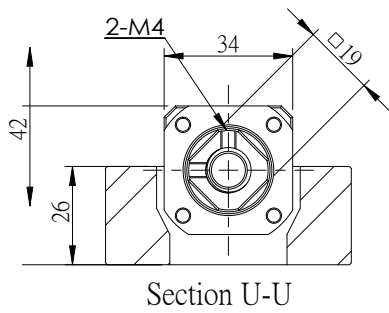

Section U-U

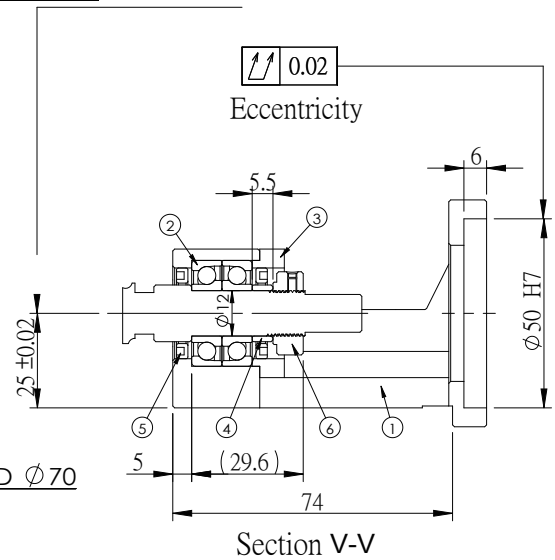
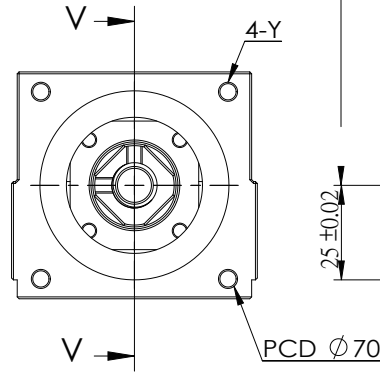

Section V-V

No.	Part name	Qty
1	Housing	1
2	7001 Bearing	1 set
3	Holding lid	1
4	Collar	2
5	Seal	2
6	Lock nut	1set
7	Cushion Stopper (option)	1

Unit : mm

Model No.	Y	Weight (Kgs)	Support unit	Suggest Coupling
			Supported-side	
MBCB12-D	M5	0.8	BF12	SGS 34C
MBCB12-DP	M4			

Note :

1. The matched bearing in the support unit has already done the preload.
2. The matched P5 bearings are assembled in DF way, which is the most suitable for ball screw use.