

Motor Bracket MBCB15

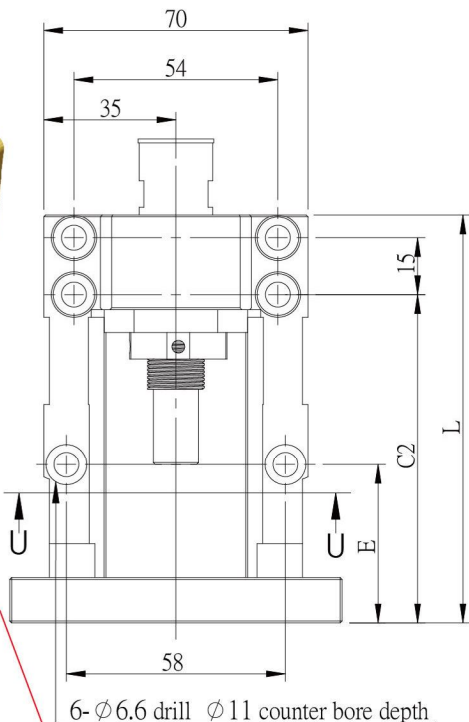
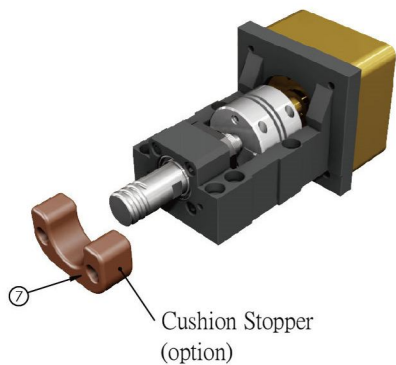

Surface treatment:
Black Oxide /
Electroless Nickel Plating

No.	Part name	Qty
1	Housing	1
2	MBCB15 Bearing 7002	1set
	MBCB15M Bearing 7202	
3	Holding lid	1
4	Collar thin thickness 10	1
	Collar thin thickness 6	2
5	Seal	2
6	Lock nut	1set
7	Cushion Stopper (option)	1

Load+35%

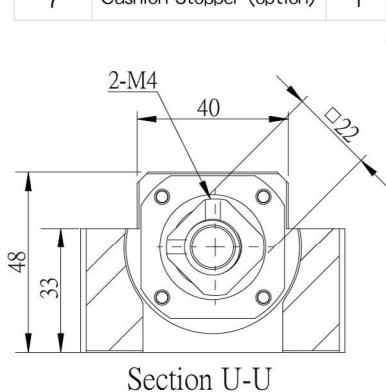

Section U-U

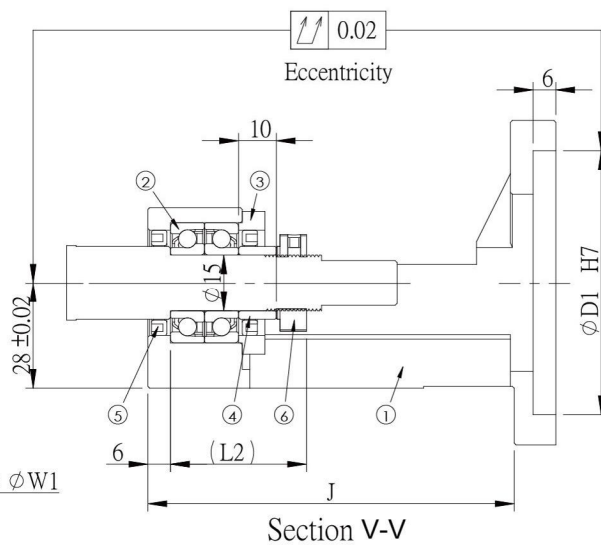
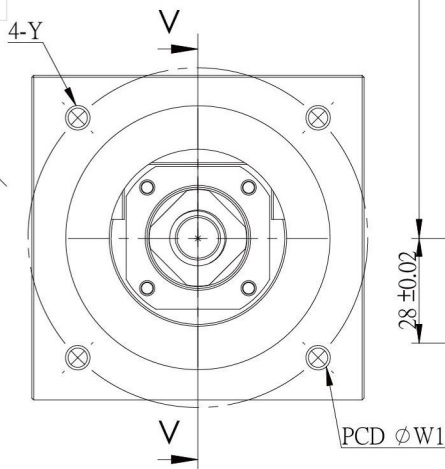

Section V-V

Unit : mm

Model No.	D1	W1	Y	L	L2	E	C2	J	Weight (Kgs)	Support unit	Suggest Coupling
										Supported-side	
MBCB15-D	50	70	M5	98	36	32	77	89	0.98	BF15	SGS 34C SGS 40C
MBCB15-DP			M4								
MBCB15-E	70	90	M6	108	36	42	87	97	1.39	BF15	SGS 40C SGS 45C
MBCB15-EP			M5								
MBCB15M-E	70	90	M6	110	40	44	89	99	1.46	BF15	SGS 40C SGS 45C
MBCB15M-EP			M5								

Note :

1. The matched bearing in the support unit has already done the preload.
2. The matched P5 bearings are assembled in DF way, which is the most suitable for ball screw use.