

Motor Bracket MBCE15

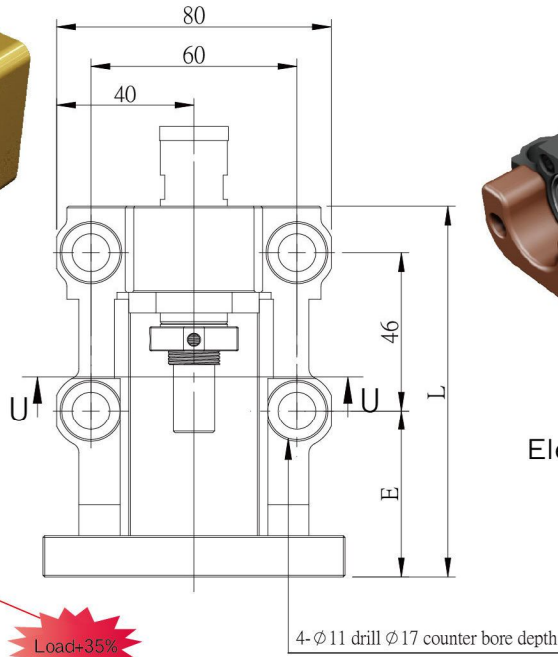

Surface treatment:
Black Oxide /
Electroless Nickel Plating

No.	Part name	Qty
1	Housing	1
2	Bearing	1 set
	MBCE15 with bearings 7002	
	MBCE15M with bearings 7202	
3	Holding lid	1
4	Collar	2
5	Seal	2
6	Lock nut	1set
7	Cushion Stopper (option)	1

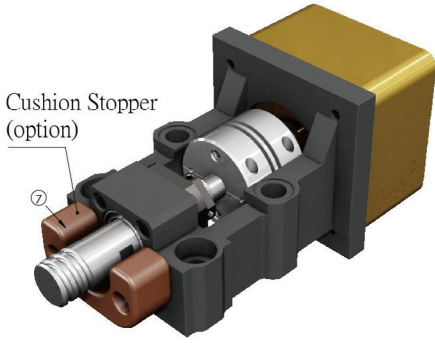
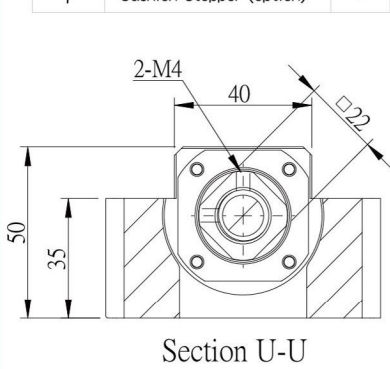

Section U-U

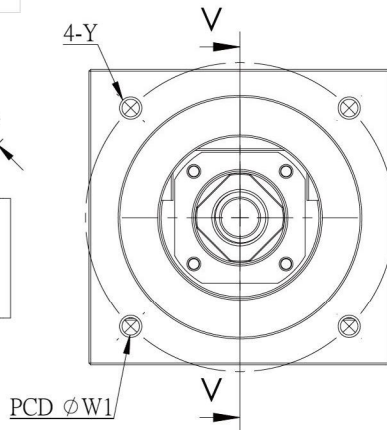

PCD φW1

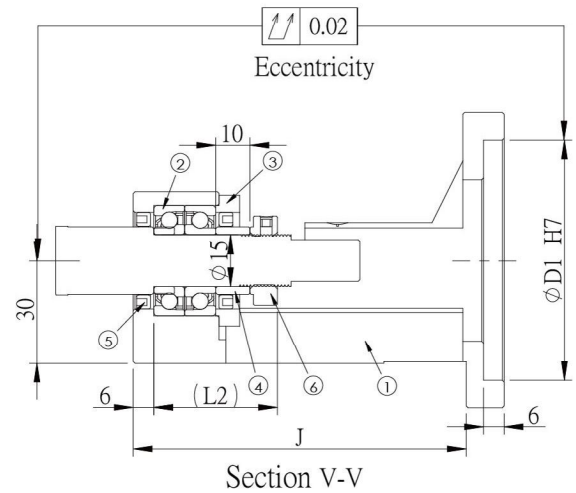

Section V-V

Unit : mm

Model No.	D1	W1	Y	L	L2	E	J	Weight (Kgs)	Support unit	Suggest Coupling
									Supported-side	
MBCE15-D	50	70	M5	98	36	38.5	flat	1.09	EF 15 AF 15	SGS 34C SGS 40C
MBCE15-DP			M4							
MBCE15-E	70	90	M6	108	40	48.5	97	1.54	EF 15 AF 15	SGS 40C SGS 45C
MBCE15-EP			M5							
MBCE15M-E	70	90	M6	110	40	50.5	99	1.61	EF 15 AF 15	SGS 40C SGS 45C
MBCE15M-EP			M5							

Note :

1. The matched bearing in the support unit has already done the preload.
2. The matched P5 bearings are assembled in DF way, which is the most suitable for ball screw use.