

# Motor Bracket MBCS35/40

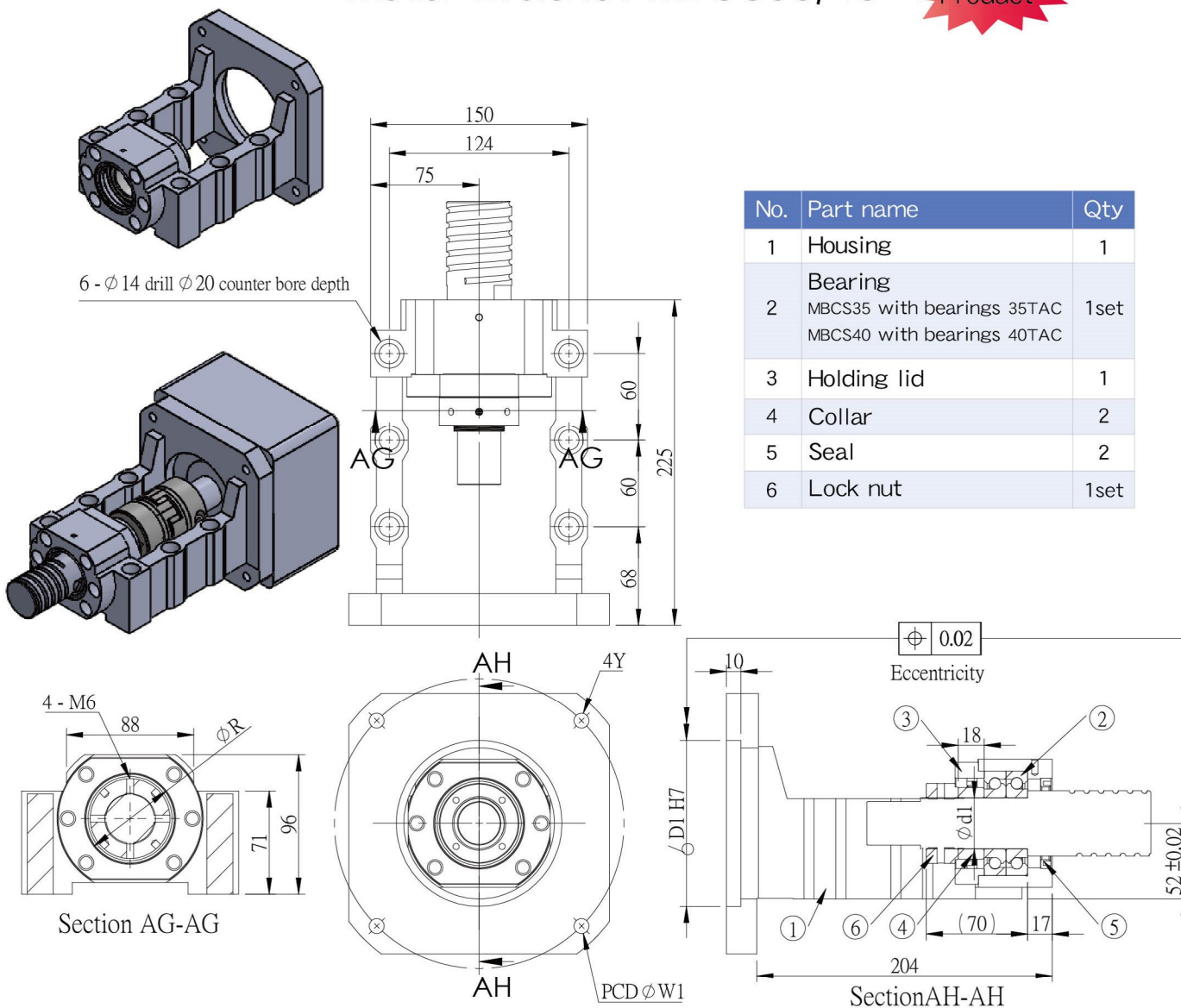

No.	Part name	Qty
1	Housing	1
2	Bearing MBCS35 with bearings 35TAC MBCS40 with bearings 40TAC	1set
3	Holding lid	1
4	Collar	2
5	Seal	2
6	Lock nut	1set

Unit : mm

	Model No.	D1	W1	Y	Shaft diameter d1	R	Weight (Kgs)	Support unit	Suggest Coupling
								Supported-side	
※	MBCS35-G	110	145	M8	35	Ø55	-	SBK35 BF35	ROTEX GS38 ROTEX GS28 MTC-65C-RD
	MBCS35-I	130	165	M10					
	MBCS35-J	150	185	M10					
	MBCS35-H	114.3	200	M12					ROTEX GS28 MTC-65C-RD
※	MBCS40-G	110	145	M8	40	Ø60	8.5	SBK40 SF40	ROTEX GS38 ROTEX GS28 MTC-65C-RD
	MBCS40-I	130	165	M10					
	MBCS40-J	150	185	M10					
	MBCS40-H	114.3	200	M12			10.4		ROTEX GS28 MTC-65C-RD

※Customized.

Note :1. The matched bearing in the support unit has already done the preload.

2. The matched P5 bearings are assembled in DF way, which is the most suitable for ball screw use.