

Motor Bracket MBL (Low Narrow Type)

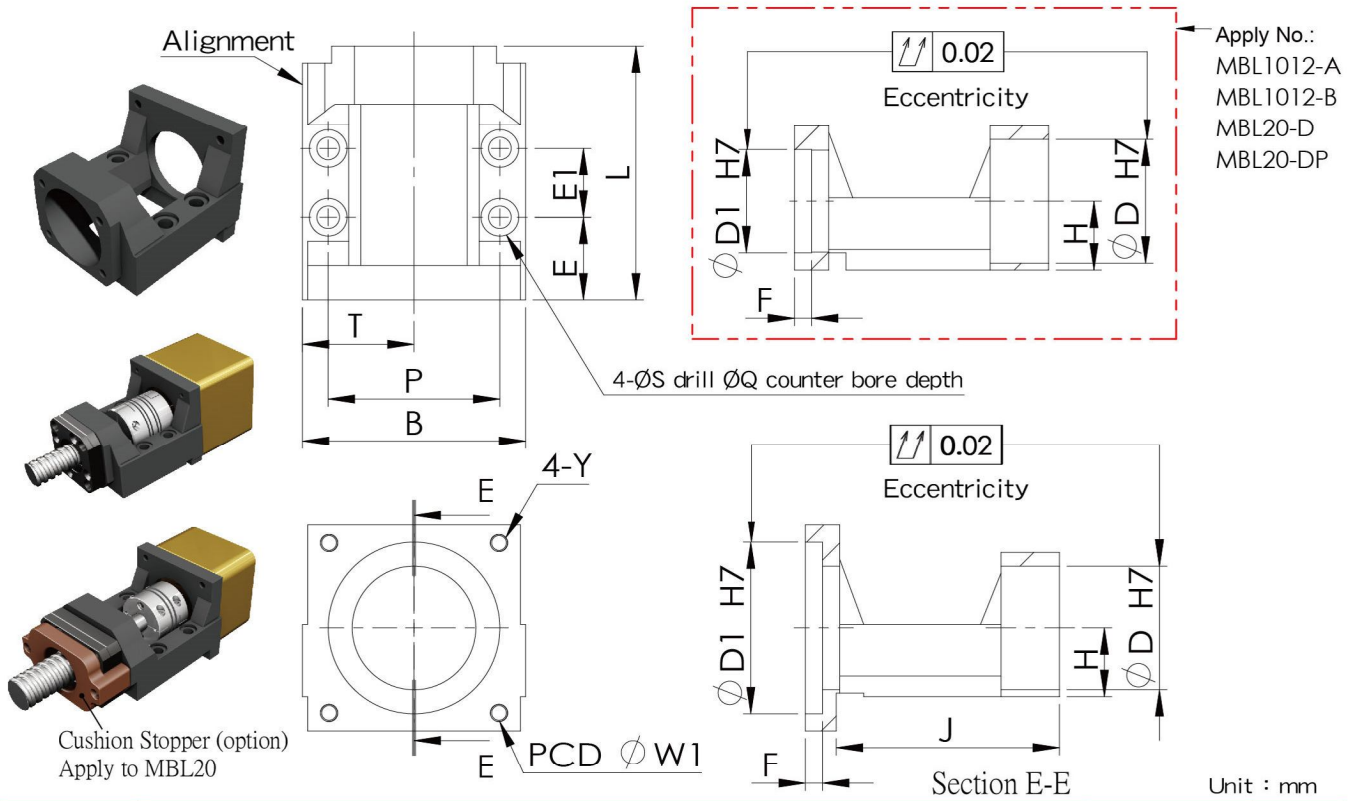

Model No.	Dimensions of Motor Bracket																Support unit		Suggest Coupling									
	D1	W1	Y	D	L	H ±0.02	B	P	T	S	Q	E	E1	F	J	Weight (Kgs)	Fixed-side	Supported-side										
MBL6/8-A	30	45	M3	28	61	15.5	52	41	26	5.5	9.5	19	20	5	54	0.27	FKA06 FKA08	LF08 LFA12	SGS 27C									
MBL6/8-B		46	M4																									
MBL10/12-A	30	45	M3	36	74	20	65	50	32.5	6.6	11	24	20	5	flat	0.57	FKA10 FKA12	LF12 LFA15	SGL 27C									
MBL10/12-B		46	M4																									
MBL10/12-C	38.1	66.7	M4	40	82	22	88	70	44	8.5	14	29	28	6	81	1.15	FKA15	LF15 LFA20	SGS 34C									
MBL10/12-D	50	70	M5																	92	70	44	8.5	14	30	6	82	1.22
MBL10/12-DP	70	90	M4																	94	70	44	8.5	14	30	6	82	1.22
MBL15-E			M6																	92	70	44	8.5	14	30	6	82	1.22
MBL15-C	38.1	66.7	M4	40	82	22	88	70	44	8.5	14	29	28	6	81	1.17	FKA15	LF15 LFA20	SGS 40C									
MBL15-D	50	70	M5																	94	70	44	8.5	14	30	6	82	1.22
MBL15-DP	70	90	M4																	92	70	44	8.5	14	30	6	82	1.22
MBL15-F			M6																	94	70	44	8.5	14	30	6	82	1.22
MBL15-E	70	90	M5	92	70	44	8.5	14	30	6	82	1.22																
MBL15-EP	70	90	M5	92	70	44	8.5	14	30	6	82	1.22																
MBL15-E			M6	94	70	44	8.5	14	30	6	82	1.22																
MBL20-D	50	70	M5	57	113	30	88	70	44	8.5	14	29	42	5	flat	1.42	FKA20	AF20 EF20 LFA25	SGS 45C									
MBL20-DP	M4	1.41																										
MBL20-F	73	98.4	M6																	1.44								
MBL20-E	70	90	M5																	1.48								
MBL20-EP			M5	1.49																								
MBL20-X	80	100	M6	1.41	102	1.41																						

Note : 1.Can choose B angle bearings when use support unit with FKA20