

# Lock Nut

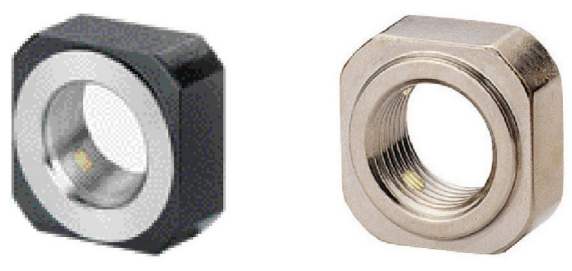

No.	Part name	Qty
1	Lock nut	1 set

## Lock Nut

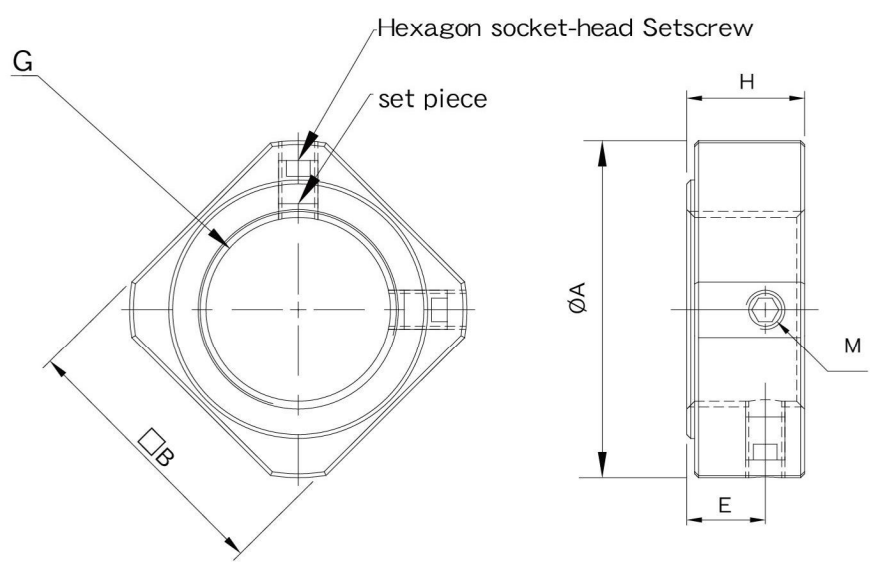

Unit : mm

Unit : mm

Model No.	H	A	E	M	B	G
RN05 RN05_N	5	12.5	2.7	M3x0.5	11	M5x0.5
RN06 RN06_N	5	13.5	2.7	M3x0.5	12	M6x0.75
RN08 RN08_N	6.5	16.4	4	M3x0.5	14	M8x1.0
RN10 RN10_N	8	19	5.5	M3x0.5	16	M10x1.0
RN12 RN12_N	8.1	22.8	5.1	M4x0.7	19	M12x1.0
RN15 RN15_N	8	25.8	4.75	M4x0.7	22	M15x1.0

Model No.	H	A	E	M	B	G
RN17 RN17_N	13	29	9	M4	24	M17x1.0
RN20 RN20_N	11	35	7	M4	30	M20x1.0
RN25 RN25_N	15	43	10	M6	35	M25x1.5
RN30 RN30_N	20	48	14	M6	40	M30x1.5
RN35 RN35_N	21	60	14	M6	50	M35x1.5
RN40 RN40_N	25	62	18	M6	50	M40x1.5

## Lock Nut (Heavy-load)



No.	Part name	Qty
1	Lock nut	1 set

## Lock Nut (Heavy-load)

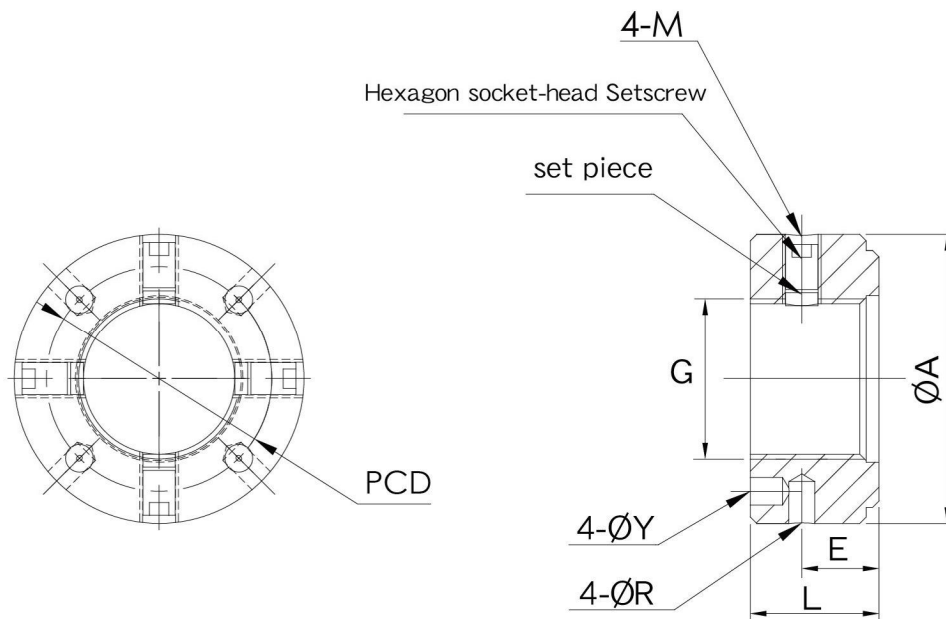

SPANNER

Unit : mm

Model No.	L	E	A	M	Y	R	PCD	G	SPANNER
RN17W RN17W_N	18	10	36	M6	4.3	4	27	M17x1.0	ZL017
RN20W RN20W_N	18	10	40	M6	4.3	4	30	M20x1.0	ZL020
RN25W RN25W_N	20	11	45	M6	4.3	5	35	M25x1.5	ZL025
RN30W RN30W_N	20	11	50	M6	4.3	5	40	M30x1.5	ZL025
RN35W RN35W_N	22	12	55	M6	4.3	5	45	M35x1.5	ZL035
RN40W RN40W_N	22	12	60	M6	4.3	5	50	M40x1.5	ZL040

# Lock Nut

Order Coding	Model No.	Surface treatment	MAX.Torque (kgf-cm)	Setscrew MAX.Torque (kgf-cm)	
RN05	M5*PO.5	Black Oxide	15	6(M3)	 <p>Black Oxide (Application : General case)</p>
RN05_N		Electroless Nickel Plating			
RN06	M6*PO.75	Black Oxide	20	6(M3)	
RN06_N		Electroless Nickel Plating			
RN08	M8*P1.0	Black Oxide	25	6(M3)	
RN08_N		Electroless Nickel Plating			
RN10	M10*P1.0	Black Oxide	30	6(M3)	
RN10_N		Electroless Nickel Plating			
RN12	M12*P1.0	Black Oxide	65	15(M4)	 <p>Electroless Nickel Plating (Application : Clean room)</p>
RN12_N		Electroless Nickel Plating			
RN15	M15*P1.0	Black Oxide	80	15(M4)	
RN15_N		Electroless Nickel Plating			
RN17	M17*P1.0	Black Oxide	95	15(M4)	
RN17_N		Electroless Nickel Plating			
RN17W	M17*P1.0 (Heavy-load)	Black Oxide	420	50(M6)	
RN17W_N		Electroless Nickel Plating			
RN20	M20*P1.0	Black Oxide	170	15(M4)	<p>Heavy-load</p>  <p>Black Oxide (Application : General case)</p>
RN20_N		Electroless Nickel Plating			
RN20W	M20*P1.0 (Heavy-load)	Black Oxide	460	50(M6)	
RN20W_N		Electroless Nickel Plating			
RN25	M25*P1.5	Black Oxide	210	50(M6)	
RN25_N		Electroless Nickel Plating			
RN25W	M25*P1.5 (Heavy-load)	Black Oxide	870	50(M6)	
RN25W_N		Electroless Nickel Plating			
RN30	M30*P1.5	Black Oxide	320	50(M6)	<p>Heavy-load</p>  <p>Electroless Nickel Plating (Application : Clean room)</p>
RN30_N		Electroless Nickel Plating			
RN30W	M30*P1.5 (Heavy-load)	Black Oxide	1050	50(M6)	
RN30W_N		Electroless Nickel Plating			
RN35	M35*P1.5	Black Oxide	480	50(M6)	
RN35_N		Electroless Nickel Plating			
RN35W	M35*P1.5 (Heavy-load)	Black Oxide	1450	50(M6)	
RN35W_N		Electroless Nickel Plating			
RN40	M40*P1.5	Black Oxide	720	50(M6)	
RN40_N		Electroless Nickel Plating			
RN40W	M40*P1.5 (Heavy-load)	Black Oxide	1600	50(M6)	
RN40W_N		Electroless Nickel Plating			