

# XYTHS660 X, Z Axis Ball Screw Actuator

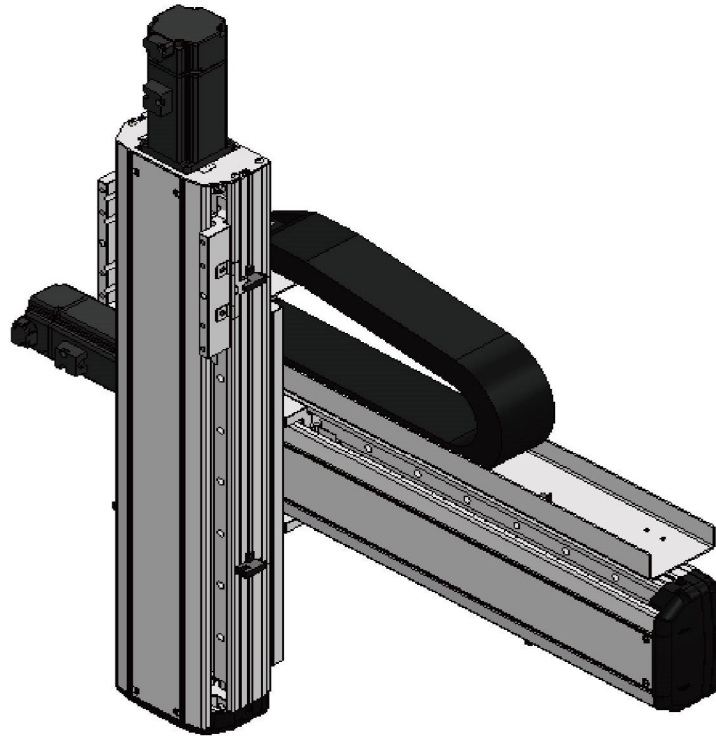

### Max. Stroke

X axis 1000mm

Z axis 400mm

### Max. Speed

X axis 500mm/s

Z axis 500mm/s

### AC Servo Motor Power

X axis 400W

Z axis 200W

### Specification

Item	X axis	Z axis
Model Type	ETHS14	ETHS14
Repeatability (mm)	±0.01	±0.01
Lead (mm)	10	10
Max. Speed (mm/s) ※3	500	500
Stroke (Gap 100 mm)	300-1000	300-400
AC Servo Motor Power (w)	400	200
Environmen	0-40°C · 85% RH Below	

※3: The Max. speed is based on 3000RPM AC servo motor.

### Max. Load Capacity

Z axis Stroke (mm)	300-400
Load Capacity of Z axis (kg)	15

## ORDER CODING

XYTHS660 - F 1 - 400 - 300 - M - C - 001

Model no.

Special Order no.

■ Combination  
F XZ Axis

■ Combination Direction  
1  
3

■ X-axis Stroke  
300-1000mm  
Gap 100

■ Z-axis Stroke  
300-400mm  
Gap 100

■ Motor Brand  
M Mitsubishi  
P Panasonic  
Y Yaskawa  
T Delta

■ Delivery Method  
C By set  
K By kit

## Combination Direction

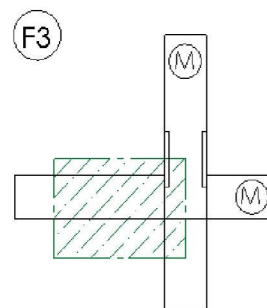
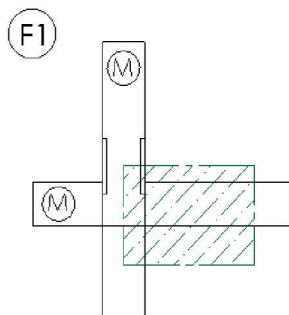

# XYTHS660 X, Z Axis Ball Screw Actuator

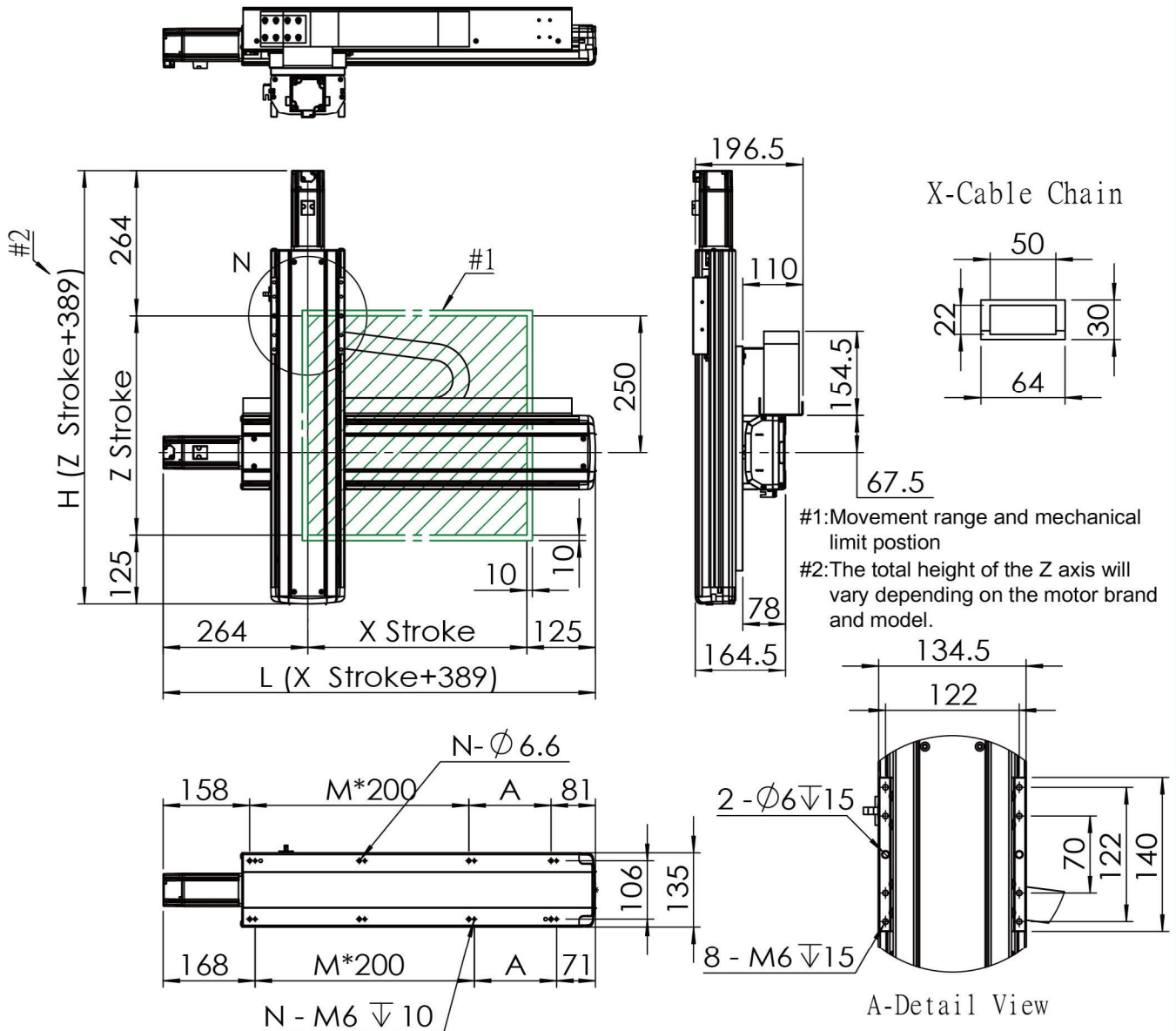

#1: Movement range and mechanical limit position  
 #2: The total height of the Z axis will vary depending on the motor brand and model.

Unit : mm

X axis Stroke	300	400	500	600	700	800	900	1000
L	689	789	889	989	1089	1189	1289	1389
A	50	150	50	150	50	150	50	150
M	2	2	3	3	4	4	5	5
N	8	8	10	10	12	12	14	14
Max. Speed	500			450			350	250

Unit : mm

Z axis Stroke	300
H	689
Max. Speed	250